

Laser gas detection is now cheap, fast and reliable

Hamish Adam, Boreal Laser and John Tulip, Univ. of Alberta
Edmonton, Alberta, Canada

Introduction

Laser based gas detectors are now being used in a wide variety of applications for process and quality monitoring, and safety and environmental compliance. The reasons are that laser detectors are more reliable and less expensive than alternative solutions.

Laser detectors combine semiconductor tunable diode lasers (TDL) and optical fibres developed by the telecommunications industry with detection techniques based on frequency or wavelength modulation (similar to radio). Laser detectors measure gas concentrations by shining a laser beam through a sample of gas and measuring the amount of laser light absorbed. Lasers emit light at a single wavelength. In TDLs the wavelength can be tuned by adjusting temperature and bias current. These properties give laser detectors an unmatched combination of selectivity, sensitivity, dynamic range and rapid response time. Boreal Laser uses some additional, unique features to make its GasFinder laser detectors less expensive, easier to use and maintenance free. As a result, GasFinder is replacing existing gas detectors and analyzers in an increasing number of applications.

Laser measurement has many benefits

The laser method has several advantages over existing gas detection techniques (see Table 1). For practical purposes, lasers generate light at a single wavelength. Room temperature TDLs emit light in the near infrared (NIR). Many gases of interest absorb light in the NIR. Each gas has a unique absorption signature, or spectrum, made up of a large number of individual “absorption lines” (see figure 1). A TDL can be tuned to select a single absorption line of a target gas, which does not overlap with absorption lines from any other gases. Therefore, laser gas sensing is very selective, and does not suffer from interference from other gases. The single-wavelength nature of laser light also means that laser gas analysers have a linear response over a wide dynamic range.

TDLs generate only a few mW of power. Therefore, even in open path applications, they are eye-safe. However, all this power is concentrated at one wavelength, the wavelength where gas absorption occurs. So, high signal to noise ratios are achieved, and response times are short, typically about 1 or 2 seconds. This also means that long path lengths can be used, enabling accurate measurements of very low concentrations, even with weakly absorbing gases.

Diode lasers provide all the advantages of other semiconductor devices. They are small, solid-state devices. They operate at room temperature and have long-term reliability (over 5 years). Currently, they can be obtained for any wavelength throughout the NIR (700nm to 2000nm). Because many gases absorb in the NIR, the technique is widely applicable.

The laser light from TDLs can be easily coupled into inexpensive and highly transmitting optical fibers. The light from a single laser can then be switched into several fibers, enabling multiple point measurement with a single laser gas analyzer. This leads to lower cost per measurement.

GasFinder – a laser gas analyzer with additional benefits

Boreal Laser’s GasFinder is a laser gas detector with some unique and patented features that give it significant advantages in cost, reliability and ease of use. The wavelength modulation technique used with all laser gas detectors normally requires a phase matching procedure that takes time and expertise. This procedure must be repeated every time the path length is changed. GasFinder employs a patented “No Phase Adjustment” detection technique that removes the need for this procedure. What this means is that different path lengths can be measured without requiring any adjustments to the GasFinder. This in turn means ratiometric measurements are possible. The signal from the measurement path is regularly compared with the signal from a calibration/reference cell inside the

GasFinder in order to calculate the gas concentration in the path (see figure 2). It also means that no special adjustments and no special expertise are needed to set GasFinder up for different path lengths.

A second unique aspect of GasFinder is the design and construction of a permanent **stable**, calibration cell for reactive gases (like HF). This means the ratiometric measurement will work repeatedly and reliably over years of operation. In addition, the laser in GasFinder is successively tuned to be off and then on the absorption line. When it is off the line, the reference cell measurement is equivalent to a zero check. When it is on the line, the reference cell reading is a span check. Because the calibration cell is stable, this means that:

- There is no zero or span drift.
- GasFinder can be calibrated in the factory, it does not need to be calibrated at installation, and it never needs to be calibrated again during operation.
- It is certain the target gas is being measured, and not some other gas with an adjacent absorption line – especially important when there is no target gas in the measure path.

Without a stable calibration cell, these claims cannot be made. As this is such an important feature of GasFinder, a built in diagnostic function continually checks the stability of the calibration cell.

GasFinder is currently available in two configurations. The portable GasFinder (see figure 3) consists of an integrated transmitter/receiver unit and a remote, passive retro-reflector array. The GasFinder is aligned with the retro-reflector using a two- axis instrument mount assisted by a telescopic sight and an on-board visible aiming laser. GasFinder can operate with path lengths from 1m to 1000 m. GasFinder is battery operated and weighs less than 5kg. Because of “No Phase Adjustment” technology, it takes less than 10 minutes to set up GasFinder and commence measurements. Therefore GasFinder is ideally suited for portable use, and temporary installations. GasFinder can be used for open path and across stack (or duct) measurements. The sensitivity of GasFinder to various gases is also shown in figure 3.

GasFinder MC is a multiple channel version that provides up to 8 independent measurement paths and 1 or 2 gases (see figure 4). The configuration for coupling multiple lasers into multiple optical fibers is unique and patented. The “No Phase Adjustment” technology is a requirement to make the multiple path configuration work, because the laser light is sequentially switched on to different paths of different optical length. The central control unit is a 19” rack mountable unit that contains the laser, multiplexing and data processing components. Fibre-optic cable carries the laser light to transmitter heads, which direct the beam along a path to a reflector. The return light is collected on a non-biased photo-detector. The photo current is returned to the central box using coaxial cable. The transmitter heads are therefore intrinsically safe. GasFinder MC complies with Class 1, Div 1 and Cenelec Zone 1 hazardous area certifications. GasFinder MC is available in open path, stack/duct, and process monitoring configurations. Generic applications possible with GasFinder MC are:

1. Monitoring ambient levels in multiple rooms within large facilities.
2. Perimeter and internal monitoring of high risk process units.
3. Multiple paths along a fence-line to enable accurate location of leaks, and local concentrations.
4. Multiple stack, duct or process monitoring using in-situ or extractive probes.

Both configurations have extensive built-in self diagnostics and full data communications capability. The benefits of GasFinder over other laser gas analyzers are summarized in Table 2.

Applications

GasFinder and other laser gas analyzers are being successfully applied to a growing number of gas monitoring applications that were either very difficult or not possible with other technologies (see Table 3). Several of these applications are discussed in below.

Aluminium Smelting

Aluminium smelting generates large amounts of hydrogen fluoride gas (HF). Because HF is highly toxic, most of this gas is collected and treated. However, different stages of the smelting process create more or less HF in the ambient air of the smelter building (also called pot rooms), and this HF can escape through roof vents. Therefore, worker safety and ambient air quality concerns require that HF be monitored at several locations in aluminium smelters. These include roofline monitoring, stack monitoring, scrubber efficiency and general process monitoring.

Existing techniques for pot room monitoring use labour intensive cassette sampling along the length the roof. In contrast, a GasFinder path may be set up in the roof, with data transmitted to a central control computer, and reliable, accurate HF data are recorded continuously, with little or no maintenance. In 4 separate, detailed comparative studies with major aluminium manufacturers worldwide, GasFinder HF data differed from standard cassette sampling data by less than 10% always, and usually less than 5%. Figure 5 shows typical data from a smelter.

HF Alkylation Units

HF Alkylation units in oil refineries use HF as a catalyst in making high-octane gasoline. Refineries manage HF Alkylation units very carefully. However, there is always the risk of leaks from process elements such as valves, pump seals and storage vessels (see figure 6 for example). Tanker unloading operations also provide the opportunity for HF releases. Almost all alkylation units have arrays of point sensors distributed throughout the unit. However, these sensors are maintenance intensive and have relatively slow response. In addition, a point sensor will not detect an HF release unless it is located directly in the path of that release. On the other hand, electrochemical HF sensors also respond to chlorine (Cl₂), ammonia (NH₃) and sulfur dioxide (SO₂) resulting in false alarms. GasFinder complements point sensor arrays by providing total perimeter coverage, with high sensitivity (1ppb on 100m path), fast response (1sec) and no false alarms. Typically a four path system is set up around the perimeter of the alkylation unit.

Gas Processing facilities

Large gas processing plants have many kilometres of pipeline and hundreds of valves. It is therefore not easy to find and determine the size of methane (CH₄) leaks. Using a portable GasFinder, leaks can be detected in a few hours. Gas turbine inefficiency and blow-by can be evaluated by monitoring exhaust stacks. Figure 7 shows the different values of emissions coming from a compressor station with six banks each having six turbine compressor units. Note the short time scale over which these measurements were taken. This is possible only because GasFinder is portable, and does not have to be adjusted for different path lengths.

Sulfur Plants

Sulfur plants handle high concentrations of hydrogen sulfide (H₂S). H₂S is extremely dangerous because, although people can smell it at low levels (about 5 ppb) it does not smell much worse at the exposure limit value of 10 ppm or at potentially fatal levels in excess of 100 ppm. So, smell is a very unreliable means of detecting dangerous releases. Arrays of H₂S point sensors suffer from the same problems listed earlier for HF point sensors. They respond slowly, and only if directly exposed to an H₂S cloud. Many H₂S sensors stop working in cold weather. GasFinder open path perimeter monitors complement existing H₂S point sensors, by providing immediate response to dangerous levels of H₂S, and by providing reliable operation in all climates.

Greenhouse Gas Emissions

GasFinder can monitor all the common greenhouse gases –CH₄, NH₃ and carbon dioxide (CO₂). GasFinder has been used in studies to measure contributions to global warming from agricultural operations and gas transportation.

Pipeline methane leaks

An airborne version of GasFinder detects CH₄ leaks from natural gas pipelines. The airborne detector reports CH₄ content of the air above the pipeline five times per second (equivalent to every 10 m). Ambient methane levels are about 2 ppm. A warning is indicated at 5 ppm, and an alarm sounds at 10 ppm. Figure 8 shows an instance where a significant leak was found.

Landfill monitoring

Landfill gas is created when waste in landfills decomposes. Landfill gas consists mostly of CH₄ (55%) and CO₂ (45%). CH₄ is explosive (lower limit of 4.5% in air) and is also a greenhouse gas. Therefore it is important to monitor methane emissions from landfills for both safety and environmental reasons. GasFinders have been used on many landfill studies worldwide.

Glass and Ceramics Manufacture

The manufacture of glass, bricks and ceramic tiles generates large concentrations of HF (50 to 100ppm) in furnace gases. HF in the ambient air corrodes physical plant, affects local crops, and prevents use of furnace gases as a heating medium. Pending regulations will limit stack HF emissions to 5 ppm. GasFinder MC can monitor multiple stacks and provide active control of HF scrubbing systems. This enables emission limits to be met, and hot furnace gases to be recycled.

Petrochemical and Chemical Industries

1. Safety and Environmental: GasFinders are used for monitoring HF and NH₃ emissions from fertilizer plants. At one plant a GasFinder monitors HF along an 816m fence line. GasFinders can also be used for area and stack HF monitoring in operations which make or use HF (for example, fluorocarbon manufacture). During 2000, GasFinders will measure other harmful gases like CH₄, ethylene (C₂H₄) and hydrogen cyanide (HCN) in petrochemical operations.

2. Process Monitoring: Laser analyzers are replacing existing techniques in several process monitoring applications. Lack of interferences and speed of response are the key advantages. In many process streams, the presence of contaminants at ppm levels results in off-spec product, catalyst poisoning and hence lost production. Existing on-line analyzers either cannot cope with the often corrosive environment, or respond too slowly to enable effective process control.

One example is ethylene manufacture. Ethylene has specifications (low ppm levels) for NH₃ and acetylene (C₂H₂) content, as these species destroy catalyst in polymerization reactions involving ethylene. Better control of these contaminants using laser gas analyzers can help prevent major financial losses associated with destroyed catalyst or product that cannot be sold.

Summary

Laser detectors like GasFinder have many advantages over established gas detection techniques in process, quality, safety and environmental monitoring. They do not suffer from interferences. They provide fast response and can measure a wide range of concentration values. Multiple measurement points can be coupled to a single gas analyzer using optical fibres. This leads to lower installation cost per measurement point. GasFinder uses on-board calibration, and maintenance-free operation to further reduce long term cost of ownership. It is little wonder then that GasFinder and other laser gas analyzers are replacing traditional gas analyzers and detectors in a growing number of applications across a broad spectrum of industries.

Feature	Benefit
Very high resolution	Minimum interference from other gases Linear response over wide dynamic range
Intense light source	Rapid response – typically 1 second Very sensitive – ppm to ppb levels
Lasers available throughout the NIR	Widely applicable
Solid state technology	Robust and reliable in all weather No consumables and no maintenance
Can be coupled with multiple optical fibres	Lower cost per measurement

Table 1: Benefits of laser detectors compared with other gas measurement techniques.

Patented Feature	Benefits
“No Phase Adjustment” detection technology	Enables ratiometric measurements with an on-board reference cell. No special adjustments and no special expertise are needed to set GasFinder up for different path lengths. Makes portable operation possible. Makes multiple channel operation possible.
Stable, on-board reference cell	Self calibrating – no additional calibration needed Ensures no zero or span drift. Absolute certainty that we are measuring the line of interest and not some other line nearby. Enables smart diagnostics to be implemented
Multiple path, multi laser configuration	Enables a combination of different measurements Leads to dramatically lower cost per measurement point.

Table 2: Benefits of GasFinder over other TDL detectors

Industry	Applications	Driving force
Aluminium smelting	HF monitoring in pot rooms, scrubber vents and stacks	Safety and environmental.
Oil Refining	HF monitoring in HF Alkylation units H ₂ S and NH ₃ monitoring (for example, from sour gas/water processing units).	Safety and environmental
Petrochemicals	C ₂ H ₂ and NH ₃ monitoring in ethylene. Moisture monitoring in corrosive streams. HCl monitoring in vinyl chloride plants. HCN monitoring in process streams and ambient air.	Process improvement and product quality. Safety.
Chemical	HF monitoring in HF and Fluorocarbon manufacture. Fence-line monitoring of HF and NH ₃ emissions in fertilizer and ammonia operations. Process monitoring of moisture and oxygen in harsh and corrosive streams. Ambient and process monitoring for HCl, HCN, NH ₃ and others.	Safety. Environmental. Process Improvement and product quality. Process improvement and safety.
Electric Power Generation	HF monitoring in nuclear fuel reprocessing. NH ₃ monitoring in NO _x reduction processes.	Safety. Environmental.
Gas Processing & Transportation.	H ₂ S monitoring at sour gas plants. CH ₄ monitoring at compressor stations. Airborne monitoring of CH ₄ leaks from pipelines.	Process improvement, safety and loss prevention.
Glass, Bricks and Ceramics	HF monitoring in vents and scrubber stacks.	Safety, environmental, process improvement.
Semiconductor	Monitoring HF and other toxics in fabrication. HF monitoring in CVD processes.	Environmental. Improved yield.
Waste treatment	HF and HCl monitoring from incinerators. CH ₄ monitoring in landfills.	Environmental Safety.
Agriculture	Monitoring greenhouse gas emissions (CO ₂ , CH ₄ , NH ₃) from various operations.	Environmental.

Table 3: Some applications in which laser detectors are proving to be the best solution.

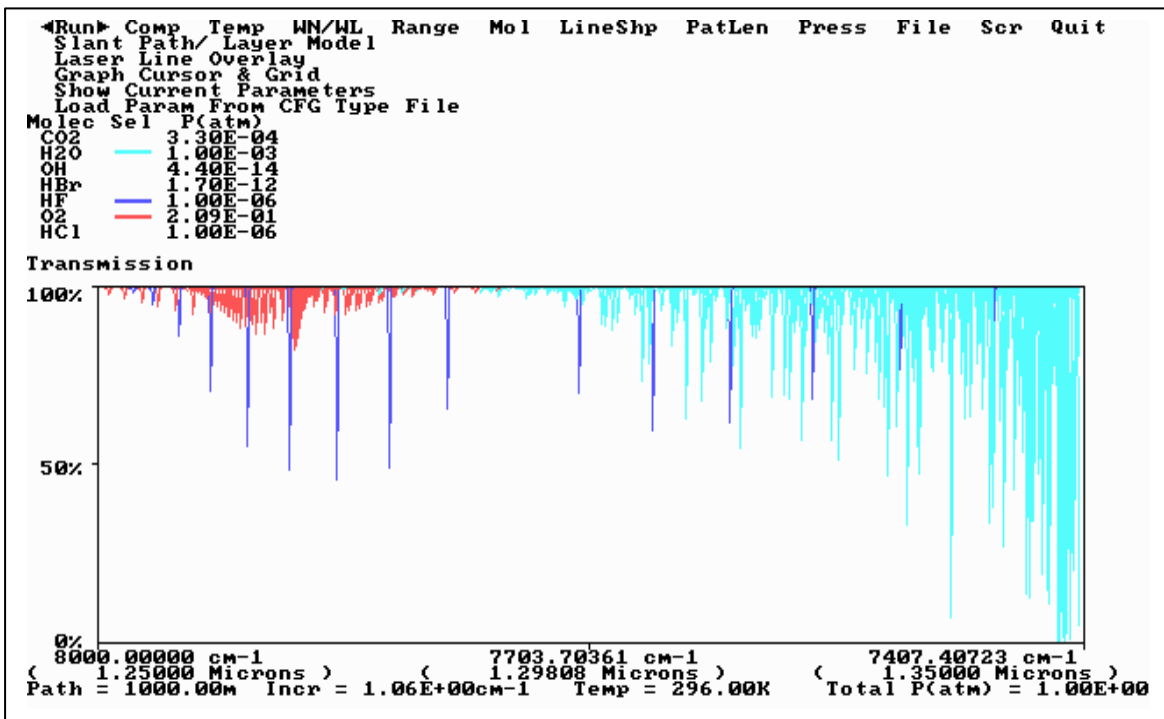

Figure 1: NIR spectrum in the 1.25 to 1.35 micron region showing HF and H2O absorption lines

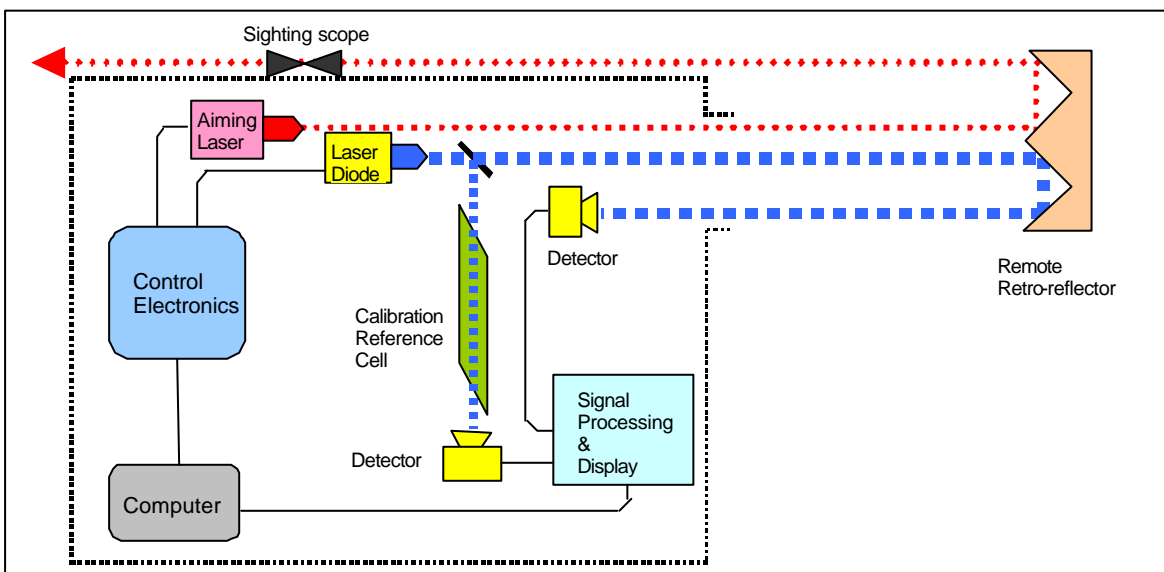

Figure 2: Schematic diagram of GasFinder. The calibration cell contains a known stable amount of the target gas. The spectrum of the gas in this cell is updated every 10 seconds. The spectrum of gas in the measure path is compared with the reference spectrum to calculate the amount of target gas in the path. Diagnostics check the stability of the reference spectrum over time.



Gas	1 m	10 m	100 m
HF	0.1	0.01	0.001
NH ₃	5	0.5	0.05
H ₂ S	20	2	0.2
CH ₄	1	0.1	0.01
CO ₂	1000	100	10
HCN	1	0.1	0.01
HCl	1	0.1	0.01
C ₂ H ₄	1	0.1	0.01
C ₂ H ₂	0.5	0.05	0.005

Figure 3: Portable GasFinder with gas sensitivities (in ppm) for path lengths of 1m, 10 m and 100m.

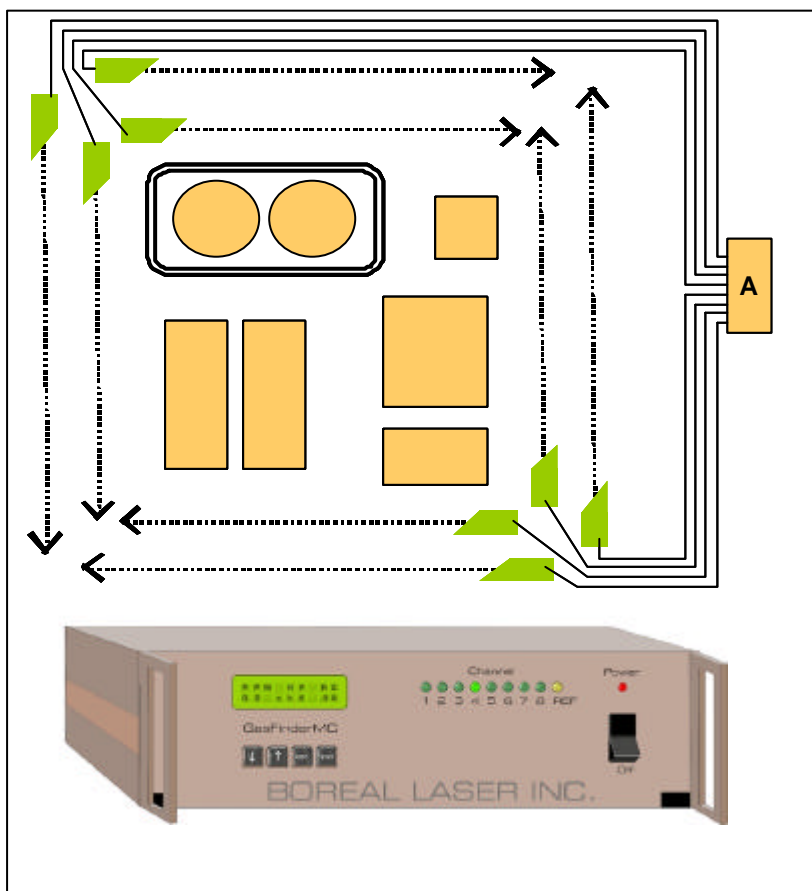

Figure 4: GasFinder MC.

GasFinder MC measures up to 8 channels with a single Central Control Unit (A) that contains the laser, multiplexing and data processing components.

Fibre-optic cable carries the laser light to measurement heads, which direct the beam along the measurement path to a reflector.

The measurement heads can be open path transmitters, in-situ probes or extractive probes.

The returned light is collected on a non biased photo-detector. The photo current is returned to the central box using coaxial cable.

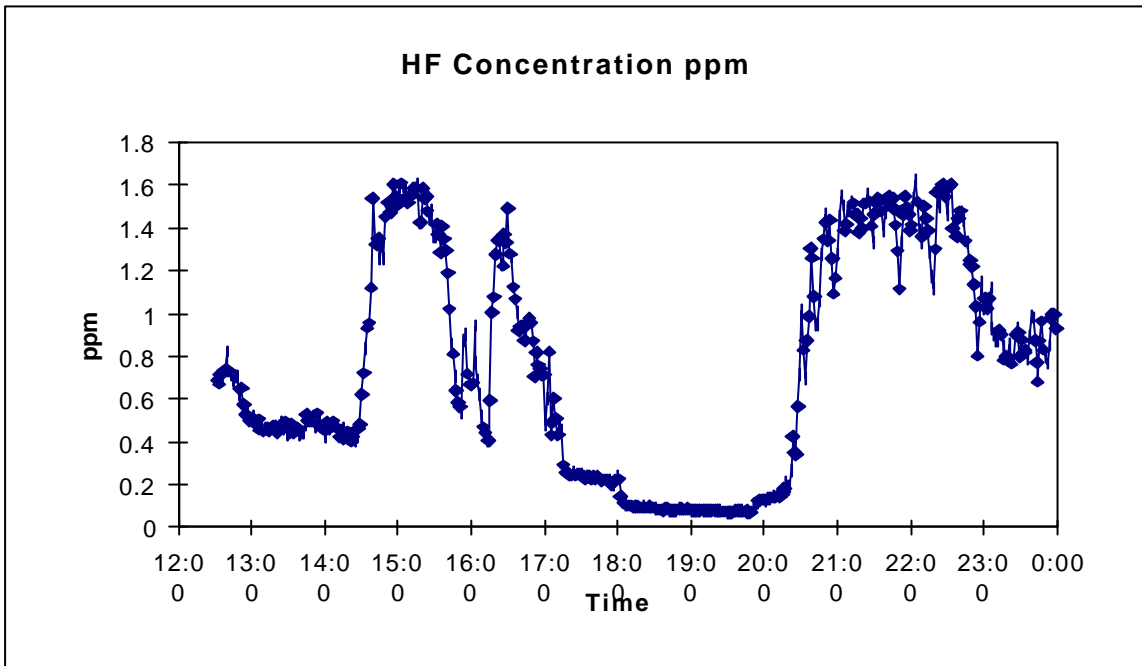

Figure 5: The concentration of HF gas in the ceiling of an aluminium smelter over a 12 hour period. From 14:20 to 16:35 anodes were being changed; a break at 16:00 can easily be seen.

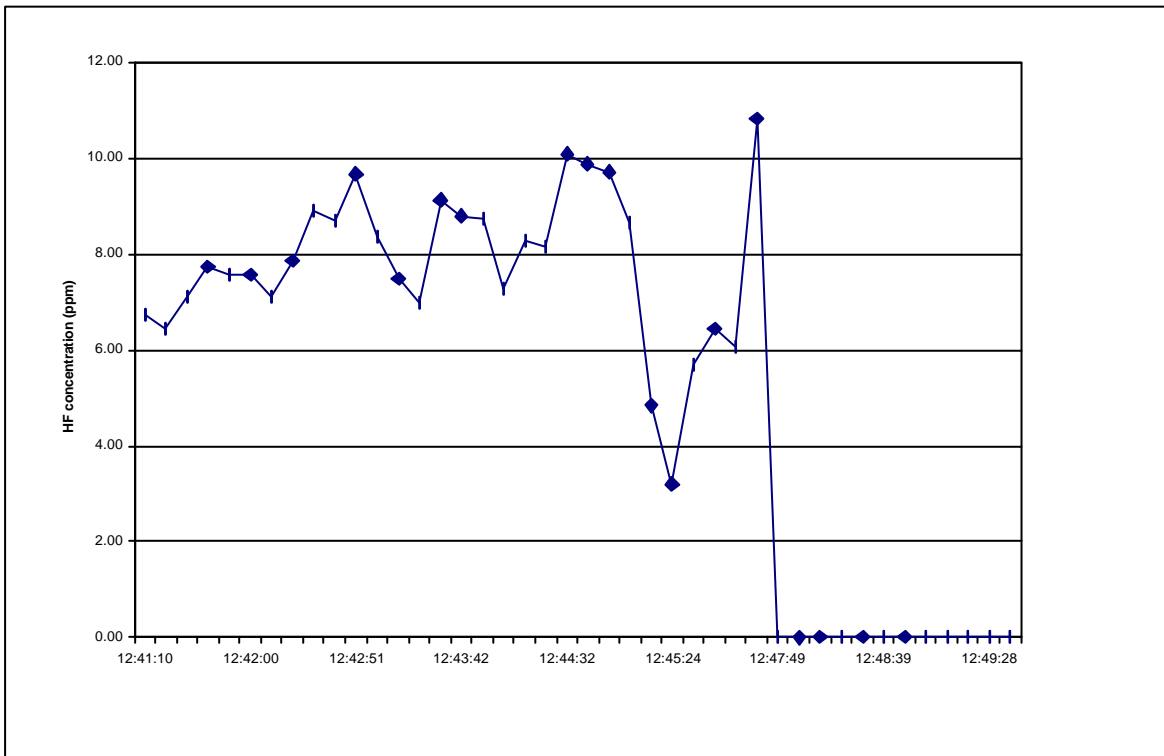

Figure 6: HF leaking from a process valve in an HF alkylation unit. GasFinder was set up downwind of the valve and measured an average of 7 ppm over a 10 m path. At 12:46 the measurement path was moved upwind and HF concentrations dropped to zero.

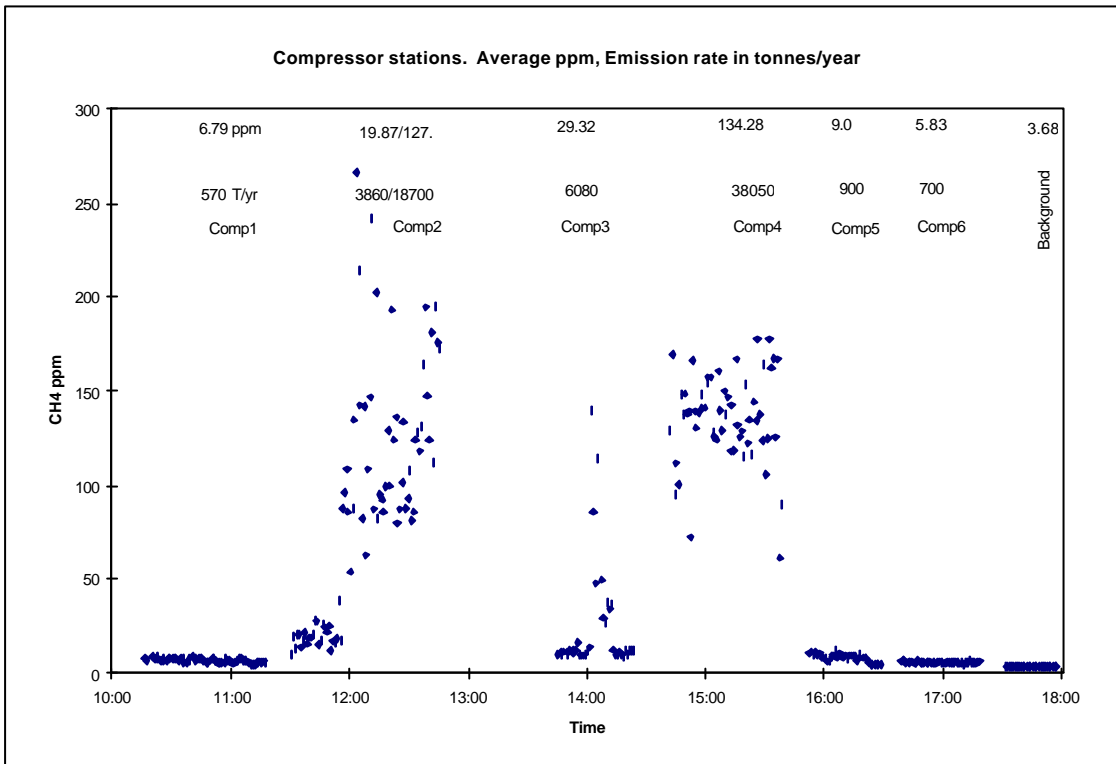

Figure 7: Displays the different downwind concentrations and emissions from five turbine compressor units. #2 and #4 are very poor, #1 and #5 are good and #6 is not operating.

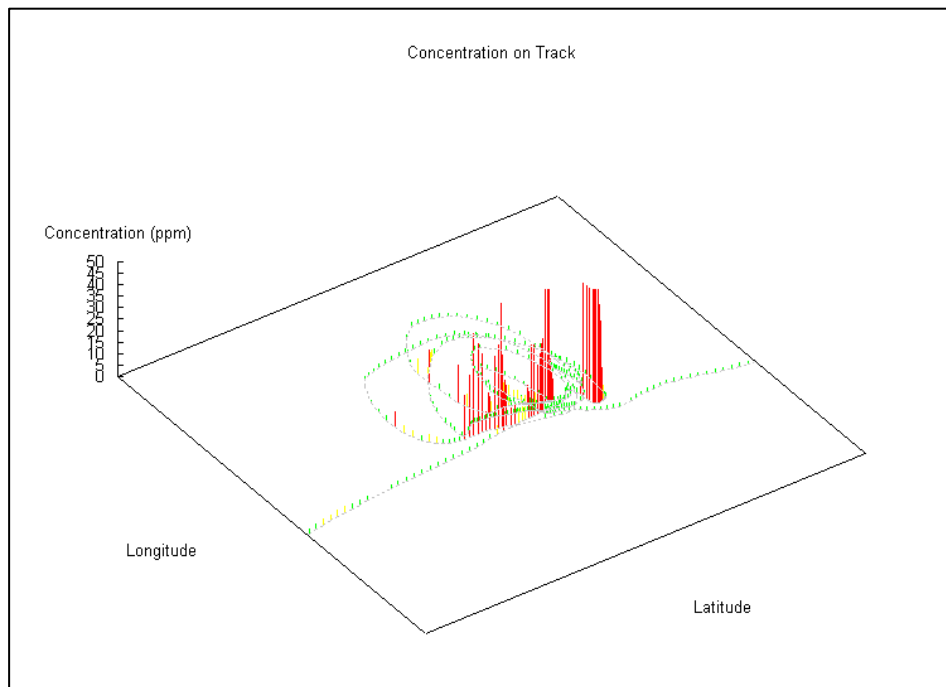

Figure 8: Airborne monitoring of methane leaks from gas pipelines. A significant leak has been discovered, the real time alarm was activated, and the helicopter pilot went back and circled the source of the leak a few times to confirm the initial reading.