

GasFinder - Technical Summary

Boreal Laser's GasFinder (US Patent 5,637,872) Open-Path Monitor measures gas concentration over an open path and consists of an integrated transmitter/receiver unit and a remote, passive retro-reflector array. The remote retro-reflector is initially targeted by the operator using a two axis instrument mount assisted by a telescopic sight and an on-board visible aiming laser.

The transceiver houses the laser diode source, drive electronics, detector module and microcomputer subsystems. The transceiver unit is contained in a weatherproof enclosure and has connectors for power input and data I/O. A schematic representation of the GasFinder system is shown below.

The laser light emitted from the transceiver unit propagates through the atmosphere to the retro-reflector and returns where it is focused onto a photodiode detector. Simultaneously, a portion of the laser beam is passed through an onboard reference cell to provide a continuous calibration update. These two optical signals are converted into electrical waveforms which the micro-controller processes to determine the actual concentration of gas along the optical path. The computed gas concentration is then displayed on the back panel of the instrument as well as being transmitted to the customer's central computer where the data may be collected, stored, and displayed.

Specifications

Weight	5 kg
Dimensions (L x W x H)	26 x 20 x 16 cm
Power Requirements	2A @ 12 Vdc
Operating Temperature Range	-30°C to +50°C
Sighting Optics	3 – 9 x 40 scope visible aiming laser
Display Options	2 x 20 character LCD
Data I/O Interface Options	RS232, 9600 baud (N-8-1) 4-20mA Current Loop
Hazardous Area Classification	Cl 1, Div 2, Gps A,B,C,D
Laser Type	semiconductor laser
Eye Safety Class (ANSI Z136)	Class I or Class IIIa

Sensitivity

HF	0.1 ppmm
H2S	20 ppmm
NH3	5 ppmm
CH4	1ppmm
CO2	1000 ppm-m
Scan Rate	1 sample/sec
Distance Range	1 - 1,000 m
Data availability	>95% per month

Sensitivities for one-second averaging.

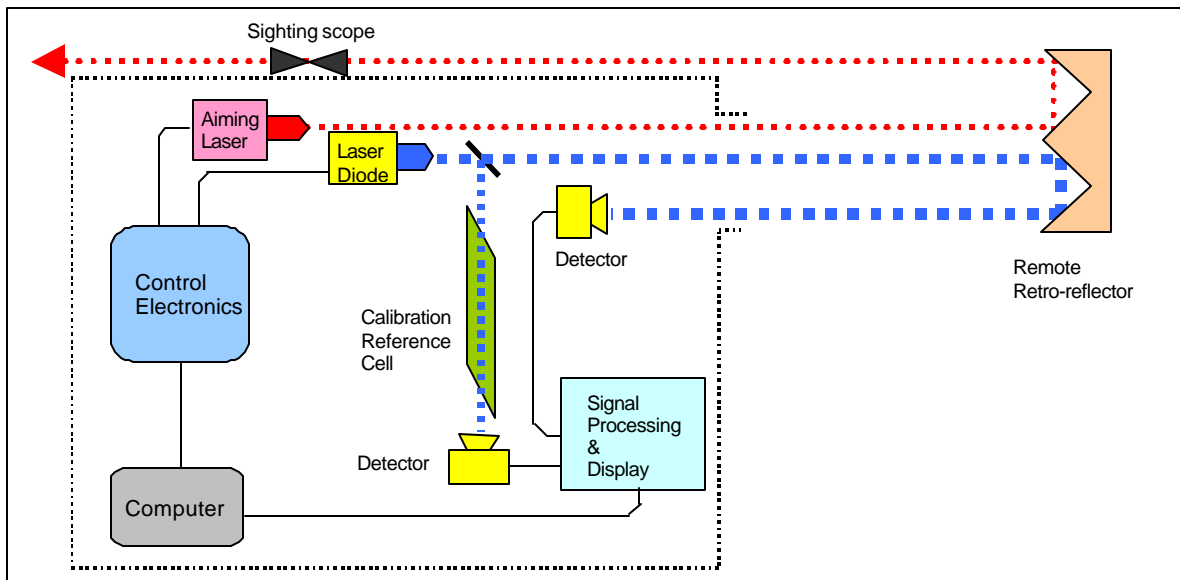

Schematic representation of GasFinder

Website: www.boreal-laser.com

Tel: 403-271-2007 Fax: 403-271-8126

E-mail: hadam@boreal-laser.com

BOREAL LASER